

Gas Struts

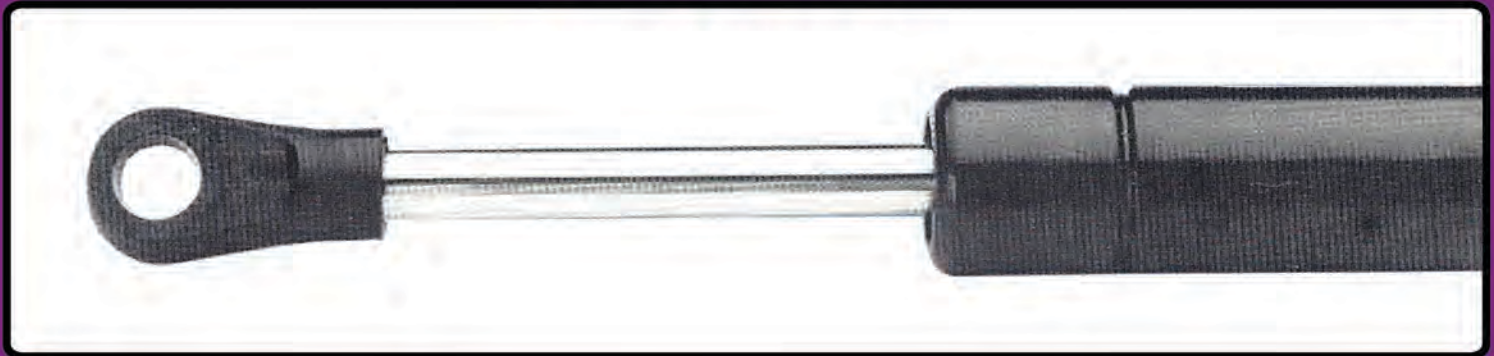

Gas struts, also known as gas springs or gas stays, have numerous applications throughout industry. They are generally used as a counterbalance for lifting lids, hatches and doors; most commonly as a support for horizontally hinged doors and panels. Typical applications include:

- Car tail-gates
- Machine Guards
- Skylights
- Coach luggage doors
- Horse boxes
- Office furniture
- Medical/rehab equipment
- Vending machines
- Control desks and panels

There are a wide range of lengths, forces and end-fittings available to suit virtually any application.

Gas struts are also available in 316 grade stainless steel for marine, off-shore, food and pharmaceutical industries.

How it Works

A gas strut comprises a piston rod which moves in or out of a pressurised sealed cylinder. Force is provided by the gas pressure acting on the cross-sectional area of the rod. The higher the gas pressure, the higher the force of the strut. An inert gas, usually nitrogen, is used for pressurising together with a small amount of oil that lubricates the seals, piston and piston rod.

When the rod is compressed or extended, transfer of gas from one side of the piston to the other is controlled by a small orifice. At the end of the extension stroke, oil damping occurs, thereby reducing sudden shocks on mountings and hinges.

“Rod down” is the preferred orientation for mounting a gas strut. This facilitates continuous lubrication of the seal and will prolong the active life of the strut.

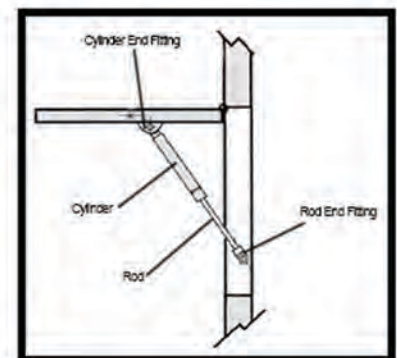

SEE PAGE 2 FOR SELECTION CRITERIA

Gas Struts

SELECTION (NEW APPLICATIONS)

- 1) Determine the weight to be lifted
- 2) From Table 1 select your required strut size.
- 3) Measure the width of door/lid ('W' on figs 1 & 2).
- 4) Referring to page 2, select a Gas Strut with a stroke approximately 25% of dimension 'W'.
- 5) Select your required end-fittings.
- 6) Add the length of your chosen end fittings to the extended length of the Gas Strut to give the overall length between centres.
- 7) Draw a layout to scale and check that your Gas Strut will fit between your proposed fixing points both in the open and closed positions. If not, adjust accordingly.

Note: Ensure that the Gas Strut does not bottom-out by only using 90% of the stroke.

- 8) Decide which of the applications shown below is most similar to yours.
- 9) Calculate the force F_1 using the appropriate formulae.

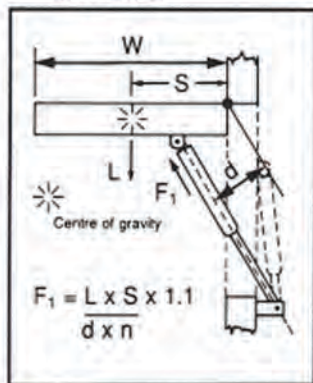

Fig. 1
 F_1 = Strut Force (extended)
 F_2 = Strut Force (compressed)
 L = Weight (N)
 S = Distance from hinge to centre of gravity

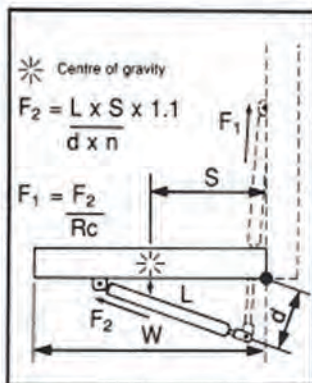

Fig. 2
 n = No of Struts used
 d = Perpendicular distance from Gas Strut to line drawn through hinge
 1 kg = 9.81N
 1 lb = 4.45N

FORCE CHARACTERISTICS

As the Gas Strut is compressed, the force increases linearly by approximately 30%. The ratio of compressed to extended force (R_c) is shown below in Table 1.

Strut Size	R_c	Door Weight
6-15	1.2	1-10 kg
8-18	1.3	6-35 kg
10-23	1.3	25-140 kg
14-28	1.5	100-350 kg
20-40	1.5	350+ kg

Table 1

ADJUSTABLE FORCE GAS STRUTS

All standard size Gas Struts shown in the table above are also available in adjustable form. They are pressurized to the maximum force for that strut size. Gas can be released via a bleed valve, accessible from the side, which allows gas to be vented, hence reducing the force. They are ideal for applications where the exact weights are unknown thus making force calculation difficult.

LIFE EXPECTANCY

For optimum life and performance:-

- * Mount the Gas Strut with the cylinder uppermost at an angle greater than 30 deg to the horizontal.
- * Eliminate side loads by using ball-joints whenever possible.
- * If using eyes, allow for some lateral movement.
- * Avoid damaging the piston rod.
- * Avoid dirty or dusty environments.

Gas Struts used in such a way on correctly engineered applications can be expected to last many tens of thousands of cycles.

For options and ordering information please see page 3.

Gas Struts

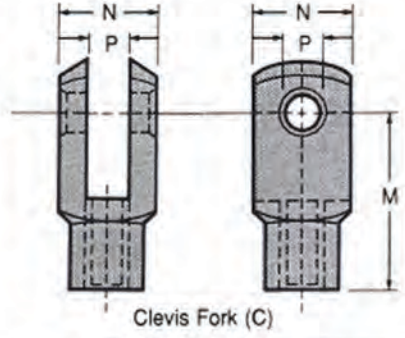
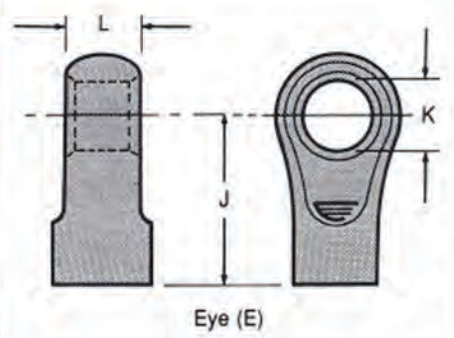
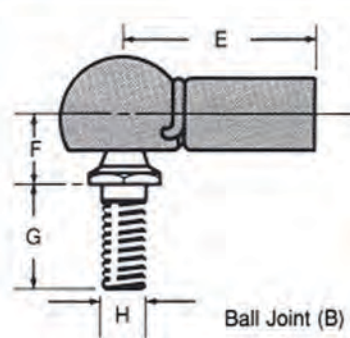
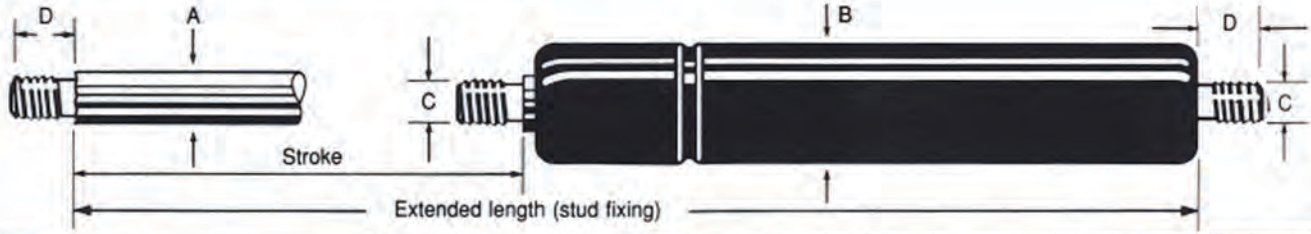

STRUT SIZE	STROKE	EXTENDED LENGTH (STUDS)	DIMENSIONS														OIL ZONE LENGTH	FORCE RANGE (N)
			A	B	C	D	E	F	G	H	J	K	L	M	N	P		
6-15	60	160	6	15	M5	8	17	9	10	M5	17	6	7	20	10	5	20	30-400N
	100	240																
	150	340																
	200	440																
8-18	100	250	8	18	M6	10	25	14	12	M8	25	8	10	24	12	6	30	75-650N
	150	350																
	200	450																
	250	550																
10-23	100	250	10	23	M8	12	25	13	16	M8	25	10	10	32	16	8	40	100-1200N
	200	450																
	250	550																
	300	650																
14-28	200	480	14	28	M10	12	35	16	20	M10	35	8	10	40	20	10	60	200-2500N
	300	680																
	400	880																
	500	1080																
20-40†	200	510	20	40	M14	18	45	20	27	M14	35	12	25 DIA	-	-	-	80	300-5000N
	400	910																
	600	1310																
	800	1710																

* All dimensions in mm

To order: Please specify part number in the format shown in the example below.

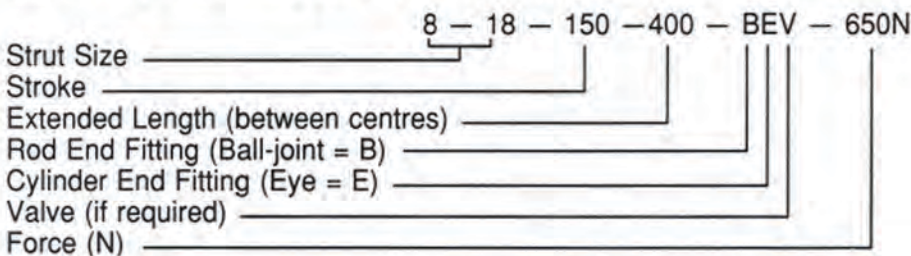

These notes are intended for general guidance only. Please refer to the relevant datasheets for full details of any of the products mentioned.