

1-270.01 Finger Pull Pr20.1

for cutout 20.1



Finger Pull for Quarter-turns.

- For head $\varnothing 28\text{mm}$ see product system 1-083, 1-095, 1-100, 1-120, 1-121, 1-210, 7-080 and 7-082. For head $\varnothing 30/32\text{mm}$ see product system 1-077, 1-081, 1-085, 1-086, 1-092, 1-100, 1-110, 1-120, 1-200, 7-080.01 and 7-084.

Material:

- **Finger Pull:** PA, black

- **With** and **without** area for company name or logo.
- With Logo on request.
- Black, other colours on request.

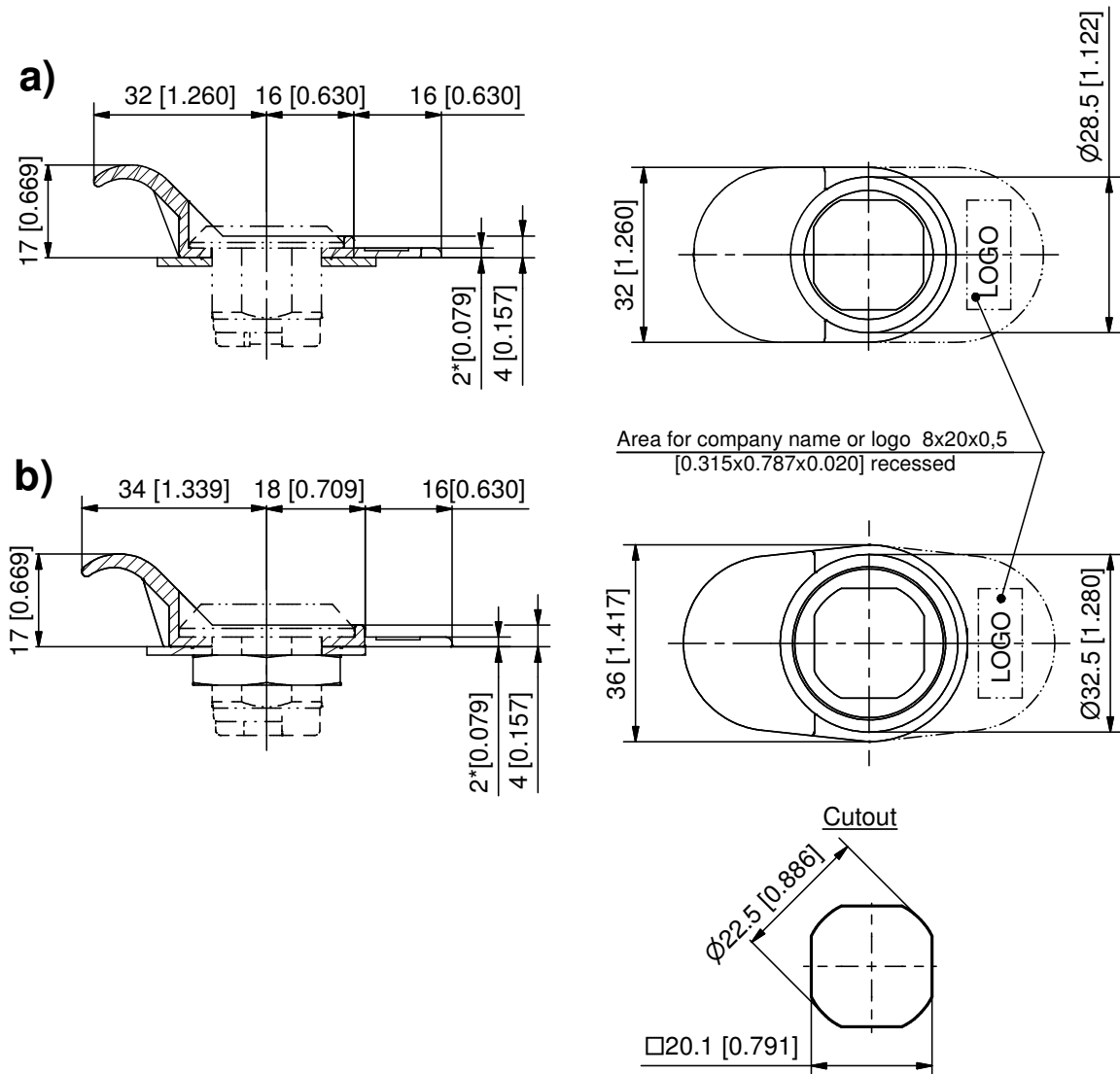

	Part No.
a) Finger pull for head $\varnothing 28\text{mm}$	
without area for company name or logo	200-4703.03
with area for company name or logo	200-4704.03
b) Finger pull for head $\varnothing 32\text{mm}$	
without area for company name or logo	200-4705.03
with area for company name or logo	200-4706.03
*Please note: By using a finger pull H-dimension changes by 2mm [0.079]	