

# 1-102 Cams L35/45

lengths 35 and 45



## Material:

Material:

- Cams: steel, zinc plated

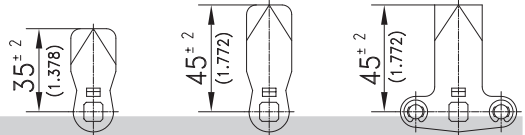
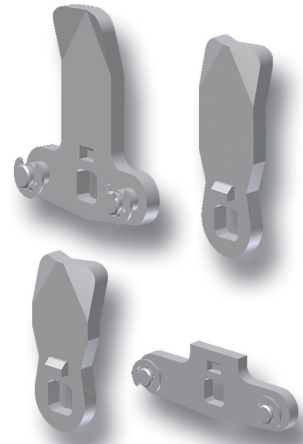
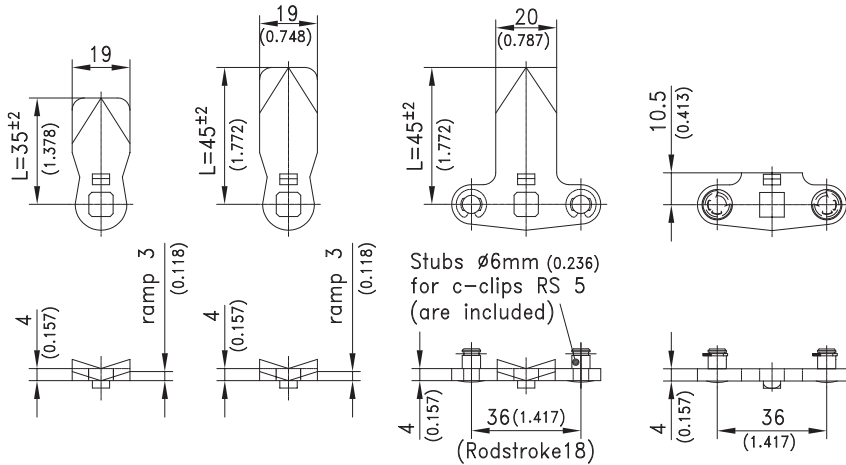

### H at housing length (GI):

GI12	GI18	GI20	GI22	GI30	GI32	GI36	GI40	GI42	GI46	GI50	GI56	GI60	GI66			
-	2	4	6	14	16	20	24	26	30	34	40	44	50	-	200-0402**	-
-	4	6	8	16	18	22	26	28	32	36	42	46	52	-	200-0404**	200-9504
-	6	8	10	18	20	24	28	30	34	38	44	48	54	200-0606**	200-0406**	200-9506
-	8	10	12	20	22	26	30	32	36	40	46	50	56	200-0608**	200-0408**	200-9508
-	10	12	14	22	24	28	32	34	38	42	48	52	58	200-0610**	200-0410**	200-9510
6	13	15	17	25	27	31	35	37	41	45	51	55	61	200-0613**	200-0413	200-9513
8	14	16	18	26	28	32	36	38	42	46	52	56	62	200-0614**	200-0414	200-9514
10	16	18	20	28	30	34	38	40	44	48	54	58	64	200-0616	200-0416	200-9516
12	18	20	22	30	32	36	40	42	46	50	56	60	66	200-0618	200-0418	200-9518
14	20	22	24	32	34	38	42	44	48	52	58	62	68	200-0620	200-0420	200-9520
16	22	24	26	34	36	40	44	46	50	54	60	64	70	200-0622	200-0422	200-9522
18	24	26	28	36	38	42	46	48	52	56	62	66	72	200-0624	200-0424	200-9524
19	25	27	29	37	39	43	47	49	53	57	63	67	73	200-0625	200-0425	200-9525
20	26	28	30	38	40	44	48	50	54	58	64	68	74	200-0626	200-0426	200-9526
22	28	30	32	40	42	46	50	52	56	60	66	70	76	200-0628	200-0428	200-9528
24	30	32	34	42	44	48	52	54	58	62	68	72	78	200-0630	200-0430	200-9530
26	32	34	36	44	46	50	54	56	60	64	70	74	80	-	200-0432	200-9532
28	34	36	38	46	48	52	56	58	62	66	72	76	82	-	200-0434	200-9534
29	35	37	39	47	49	53	57	59	63	67	73	77	83	200-0635	200-0435	200-9535
30	36	38	40	48	50	54	58	60	64	68	74	78	84	-	200-0436	200-9536
32	38	40	42	50	52	56	60	62	66	70	76	80	86	200-0638	200-0438	200-9538
34	40	42	44	52	54	58	62	64	68	72	78	82	88	200-0640	200-0440	200-9540
36	42	44	46	54	56	60	64	66	70	74	80	84	90	200-0642	200-0442	200-9542
38	44	46	48	56	58	62	66	68	72	76	82	86	92	200-0644	200-0444	200-9544
39	45	47	49	57	59	63	67	69	73	77	83	87	93	-	200-0445	200-9545*
41	47	49	51	59	61	65	69	71	75	79	85	89	95	-	200-0447	200-9547*
44	50	52	54	62	64	68	72	74	78	82	88	92	98	-	200-0450	200-9550*
47	53	55	57	65	67	71	75	77	81	85	91	95	101	-	200-0453	-
49	55	57	59	67	69	73	77	79	83	87	93	97	103	-	200-0455	-

\*Price and delivery time on request!

### \*\*PLEASE NOTE:

These cams cannot be used with slide shoe product system 1-103SL.

	Part No.	see page
2-point cam, steel, zinc plated	200-9599	
Cam with ramp H=18, L=25	200-5118	02.80
Hooked Cams		02.81
Other cams		02.82, 03.45
Cam for alternative solution		03.46
Stainless steel cams		10.16