

7-035 T- and L- Handle

for cutout A, for flat rods, stainless steel AISI 316



T- and L-Handles for application with Rod latch system shown on product system 7-030.

Material:

- **Handles, escutcheon, screws, washer and grounding device:** stainless steel AISI 316
- **Grounding clip:** stainless steel AISI 301
- **Cylinder barrel:** zinc die, chrome plated



a)

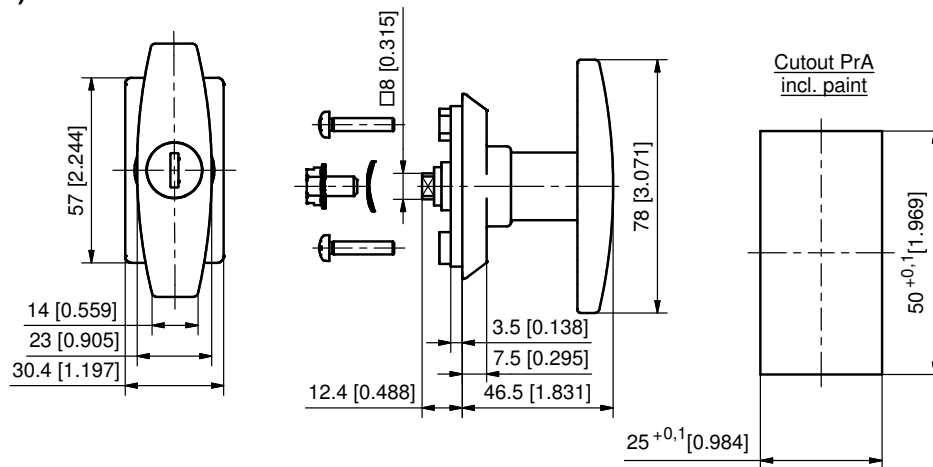

b)

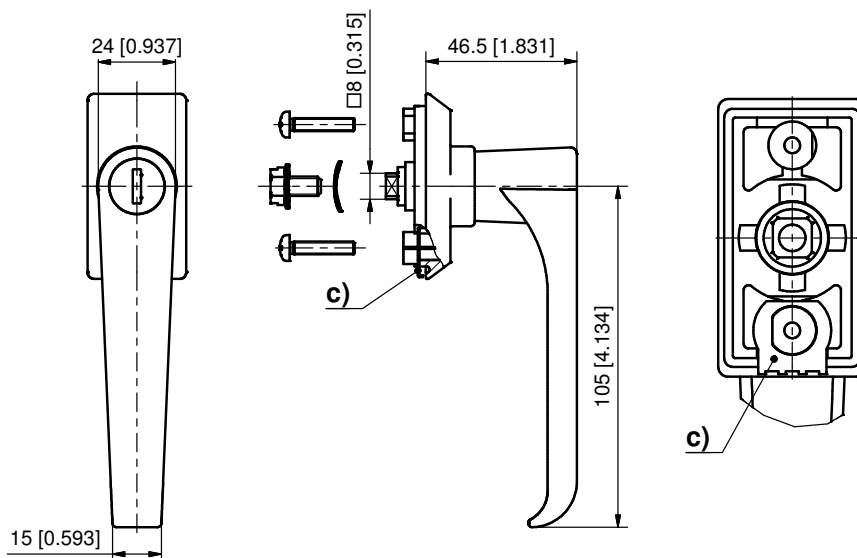

version	a) T-Handle	b) L-Handle	see page
non locking	208-9634	208-9635	
keyed alike DIRAK 1333	208-9650	208-9652	
keyed different/mixed	208-9651	208-9653	

All lockable handles supplied with two keys.
Screws and washers are included.

Optional:

c) O-Ring for cutout PrA (50x25mm)	208-1802	208-1802	
d) Grounding clip	208-1206.93	208-1206.93	3-011