

# 5-160 Edge Protections

PVC

Edge protections are used when steel edges have to be smooth.

- Additional metal machining work can be avoided and an decorative effect is achieved.
  - Edge protection profiles are flexible.
  - The U-shaped steel clip-on tape with a PVC jacketing provide for firm seating on metal edges, even if there are radii or bends.
  - The profile is simply pressed onto the metal edge by hand, so there is no need for tools, adhesives or connecting elements.
  - Edge protection profiles differ in shape, size, color and surface, depending on the application.
- The PVC jacketing is resistant to weathering and to temperatures within a range from approx. -40° to +70° Celsius.
  - Tolerances: see page 07.07.
  - **Customized designs:**
  - If the cross-sections shown here are not suitable for your specific application, we can produce a customized profile to meet your needs.
  - Other colors are available on request.



**Material:**

- **Edge protection:** PVC with steel spring core

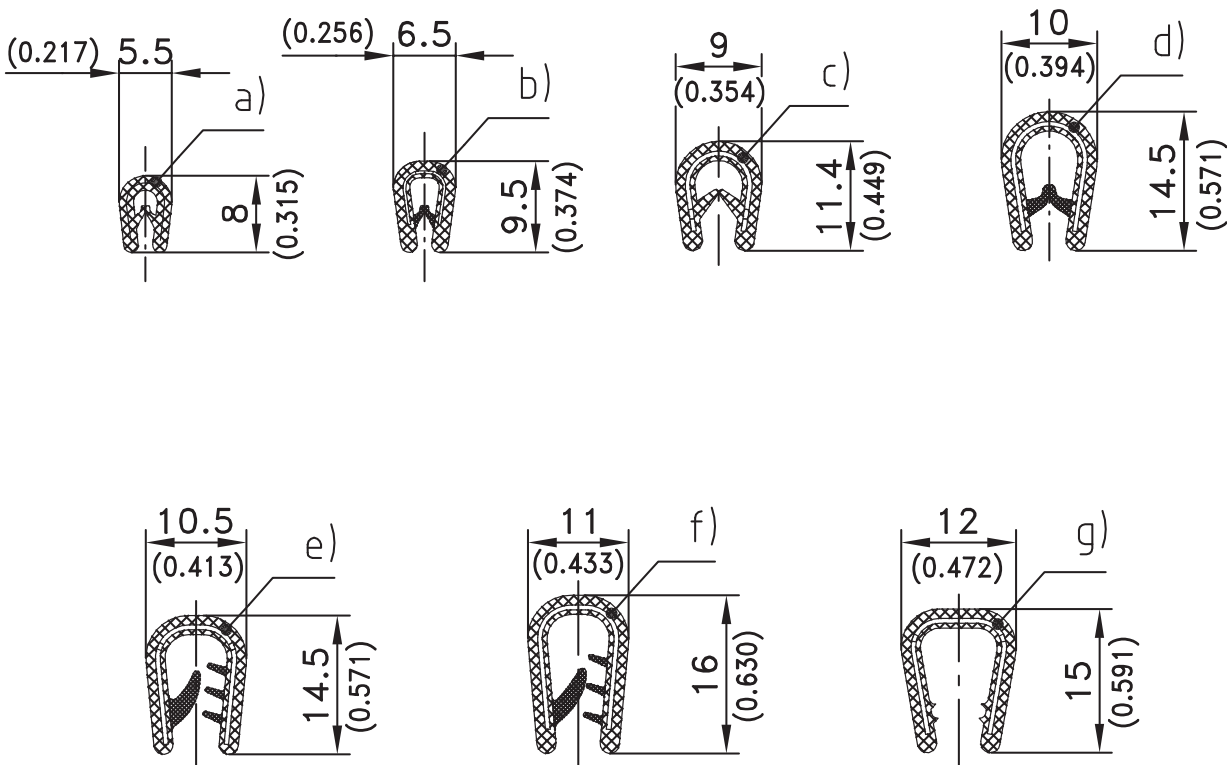

color	clamping range	packaging unit	Part No.
a) black, smooth	0.8 - 1.5mm	50m	209-0801
b) black	1.0 - 2.0mm	50m	209-0802
white-grey	1.0 - 2.0mm	100m	209-0805
silver	1.0 - 2.0mm	100m	209-0807
c) black	1.0 - 2.0mm	100m	209-0808
black	2.0 - 4.0mm	100m	209-0820
d) black	1.0 - 4.0mm	50m	209-0803
anthracite	1.0 - 4.0mm	100m	209-0810
light grey	1.0 - 4.0mm	100m	209-0811
white-grey	1.0 - 4.0mm	100m	209-0812
e) black	2.0 - 5.0mm	100m	209-0813
f) black	2.0 - 4.0mm	100m	209-0814
black	1.0 - 2.5mm	100m	209-0816
black	4.0 - 6.0mm	100m	209-0817
g) black	6.0 - 8.0mm	100m	209-0815
black	8.0 - 10.0mm	100m	209-0818
light grey	6.0 - 8.0mm	100m	209-0819