

# 5-150 Clip-on Sealing Profiles

EPDM / NBR



Clip-on profiles combine the characteristics of edge protection profiles and sealing profiles.

- Clip-on sealing.
- The sealing part of these profiles is made of sponge rubber and the clamp area consists of soft rubber with a steel clip-on core.
- In an extrusion process the two materials are bonded to each other through vulcanization.
- The profiles made of NBR are oil resistant.
- Tested according to UL standards.

**Customized designs:**

- If the cross-sections shown here are not suitable for your specific application, we can produce a customized profile to meet your needs.
- Sealing profile also available in UL tested material (UL94 HB).

**Material:**

- **Clip-on profiles:** EPDM or NBR
- **Carrier:** soft rubber
- **Sealing part:** Sponge rubber

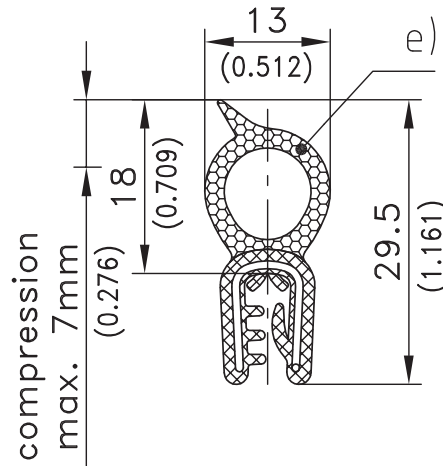
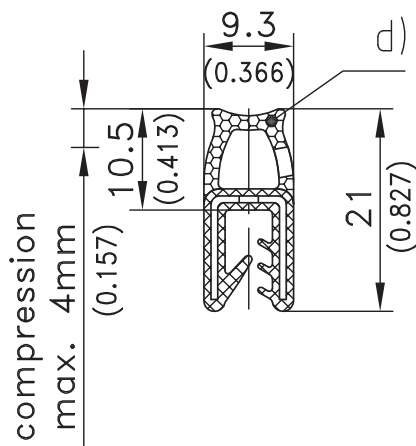
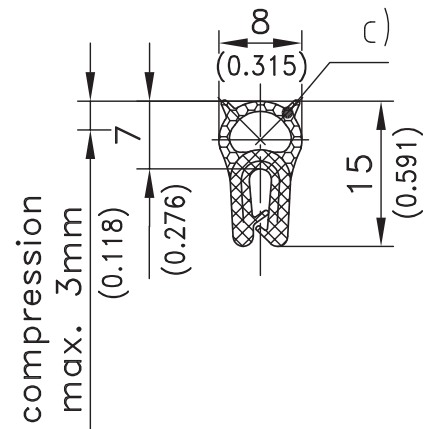
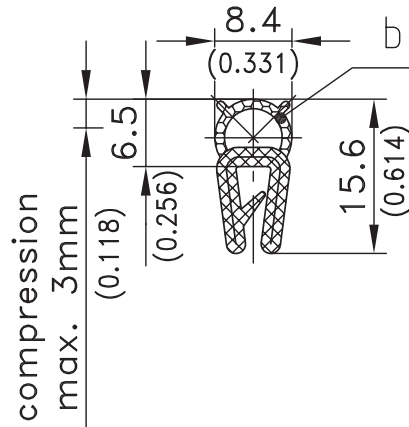
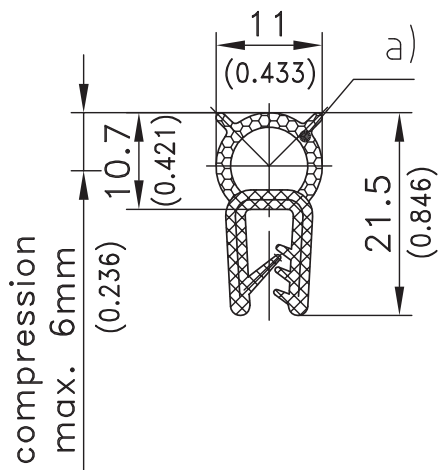
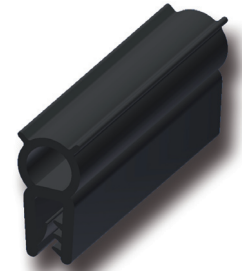

	Material	color	clamping range	packaging unit	Part No.	UL (UR)
a)	EPDM, soft- / sponge rubber	black	1.5 - 3.0mm	50m	209-0201	*
a1)	EPDM, soft- / sponge rubber	black	0.8 - 2.0mm	50m	209-0201.1A	
a2)	NBR, soft- / sponge rubber	black	1.5 - 3.0mm	50m	209-2201	
a3)	EPDM, soft- / sponge rubber	black	3.0 - 4.0mm	100m	209-0240	
b)	EPDM, soft- / sponge rubber	black	1.0 - 2.0mm	50m	209-0205	*
b1)	NBR, soft- / sponge rubber	black	1.0 - 2.0mm	50m	209-0246	
c)	EPDM, soft- / sponge rubber	black	0.8 - 1.5mm	50m	209-0205.1A	
d)	EPDM, soft- / sponge rubber	black	1.0 - 2.5mm	75m	209-0211	
e)	EPDM, soft- / sponge rubber	black	1.0 - 2.5mm	75m	209-0220	*