

4-130 Concealed Hinge Pr03 120°

door bending 20mm, for surface mounted door



120° Concealed Hinge for surface mounted door.

- RH or LH application.
- The width of the door-part allows for easy spot welding. The hinge can also be supplied with a self-securing POM pin which can be mounted upside-down for very short enclosures.
- Door-part screw-on or weld-on.
- Frame-part screw-on.

Material:

- **Frame-part:** steel, zinc plated
- **Door-part:** steel, untreated
- **Pin:** steel, zinc plated
- **Pin:** POM natural

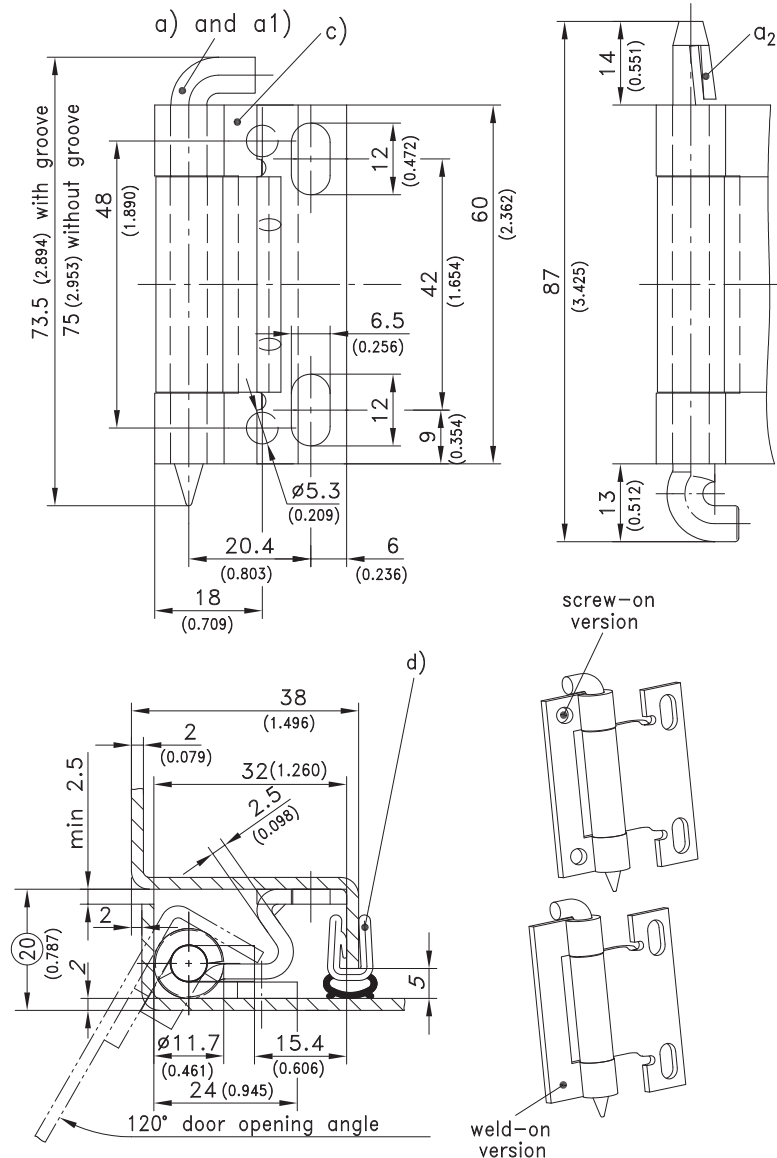

120° Hinge, door bending 20	door-part screw-on	door-part weld-on	see page
a) Pin without groove	216-9003	216-9024	
a1) Pin with groove for retaining ring	216-9011	216-9025	
a2) Pin POM self-securing	216-9006	216-9026	
Please order separately:			
b) Retaining ring DIN 6799 RS4 for pin with groove	800-0137	800-0137	
c) Door-part like roll Ø6			06.77
d) e.g. Clip-On Profiles	209-0205	209-0205	07.19
Stainless steel version			10.69