

4-392 Concealed Hinge Pr02 120°

Lift-off, for nested door, with springloaded pin



Versions LH and RH with springloaded pin for extension of the door.

- Versions Ø5mm are just welded-on.
- Versions Ø4mm and Ø6mm are welded-on or screwed-on.

Material:

- **Roller:** steel, untreated or steel, zinc plated
- **Pin:** steel, zinc plated
- **Spring:** stainless steel

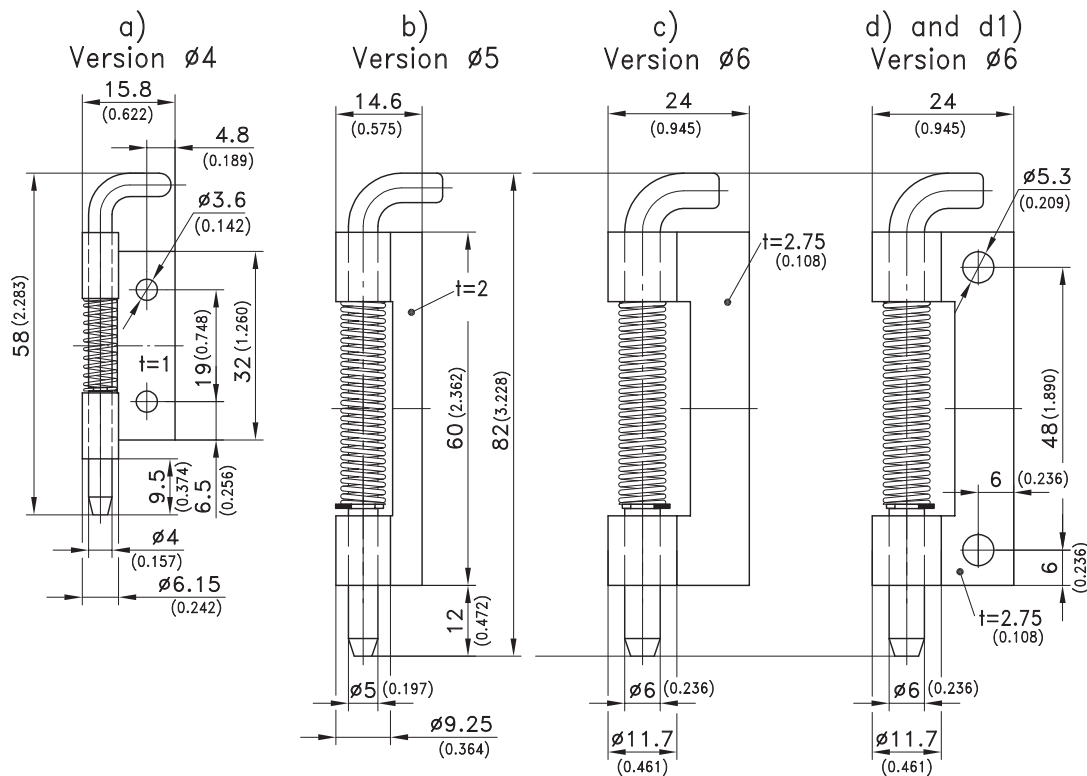

Example of application

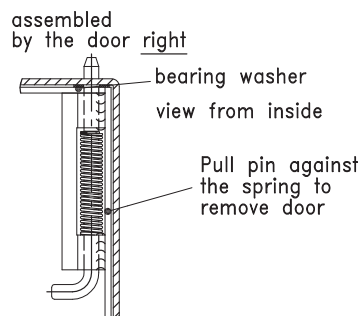

	a) Ø4	b) Ø5	c) Ø6 (Roller untreated)	d) Ø6 (Roller untreated)	d1) Ø6 (Roller zinc plated)	see page
loose parts (not assembled)	-	245-9105*	-	245-9106*	245-9109*	
version RH (as drawn)	245-9001	245-9103	245-9113	245-9101	245-9107	
version LH (mirror inverted)	245-9002	245-9104	-	245-9102	245-9108	
Stainless steel version						10.64

*Because some hinge bodies have to be welded on and painted, we offer these hinges loose, not assembled.