

7-330 Slam Latch

stainless steel AISI 316



This Flush Slam Latch is suitable for applications where corrosion protection is needed.

- The Latch is made completely of stainless steel.
- The flush design makes this latch suitable for all applications where safety is needed and where only a limited space is available.
- The hollow space below the lever allows an easy access for operating the lever.
- The latch can be unlocked one-off or permanent.
- For a one-off unlocking the lever has to be opened about 45°, the spring loaded lever automatically returns to the flush position.

- For a permanent unlocking pull the lever upwards over 45° (over center), this unlocks the latch and it stays in position "unlocked".
- Pushing the lever, brings the latch back to position "locked".
- The inside catch includes a device for unlocking from inside.
- Ⓢ-dimension 3 to 21mm. Leaving out the front spacer increases the Ⓢ-dimension by 3.4mm. The included screw has to be shortened accordingly.



Material:

- **Housing, handle and latch:** AISI 316, surface polished
- **Screw, cam angle, pin and spring:** stainless steel
- **Spacer:** nylon black

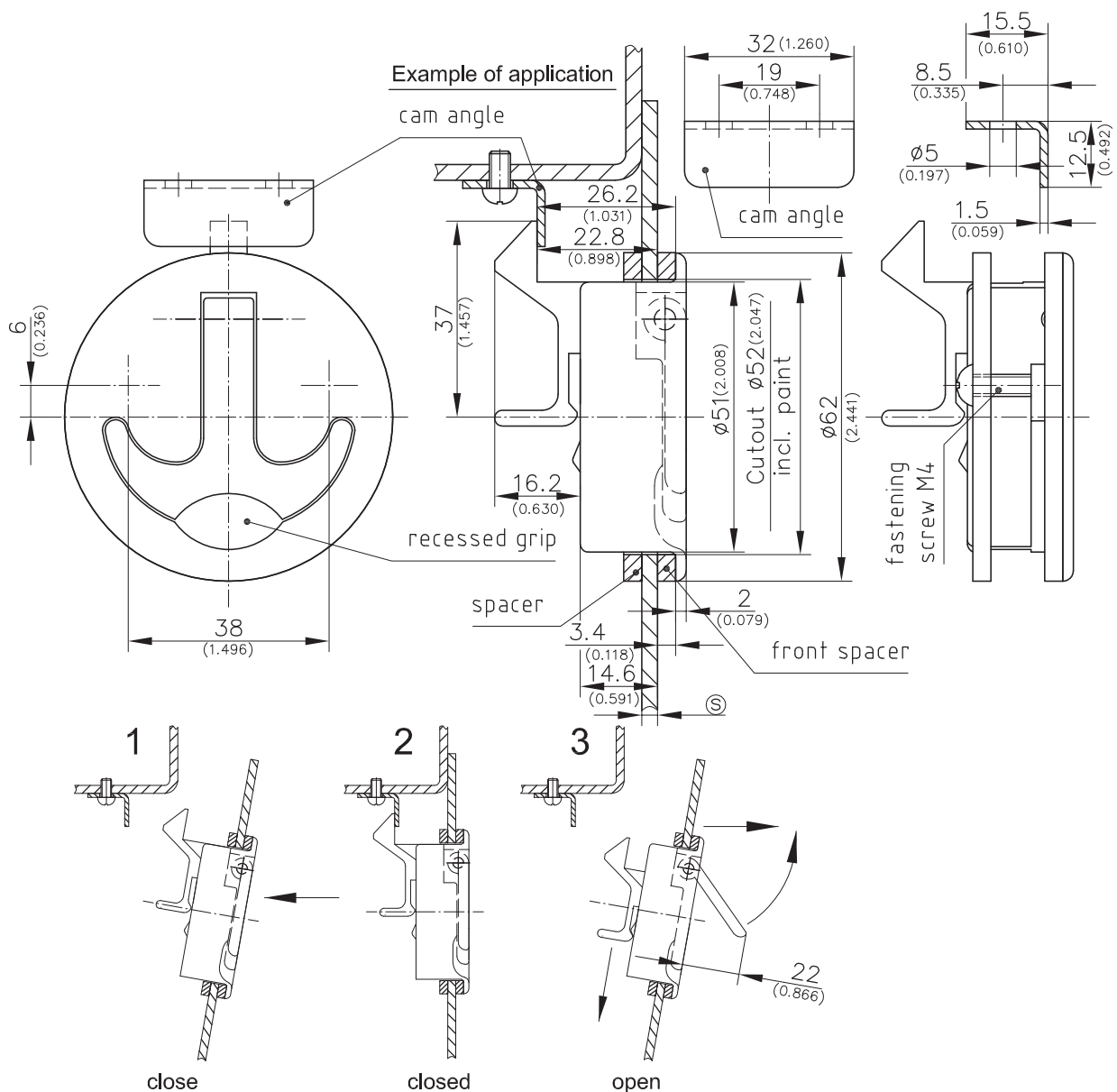

Flush slam latch

Ⓢ - dimension
3/0.118 to 21mm/0.827 (as drawn)

Part No.
282-9601.00-00000