

1-040SL Fastener 8x15 SNAP-LINE

for cutout 8x15, tool-less installation



Fastener for joining flat metal sheets.

- The joining of two metal sheets is achieved by pushing the Fastener into the cutouts.
- With tool/key Part-No.: 292-0302.70 product system 6-080SL this Fastener can be disengaged both from inside and outside.
- The tool is captive in the open position.

- The dimension \textcircled{S} always means the thickness of both sheets,
- e.g.: $1.5 + 1.5 = 3$
 $2.0 + 1.0 = 3$
 $2.0 + 2.0 = 4$

Material:

- **Housing:** PA, black or light grey,
- RAL 7035
- **Snap wedges:** Grivory, black

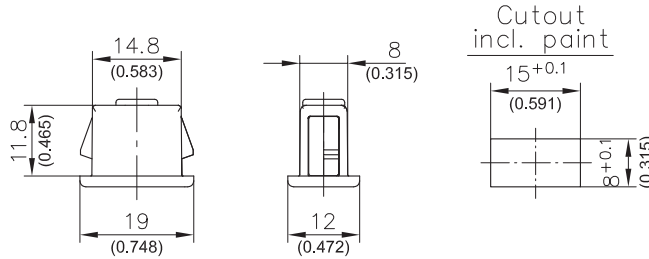
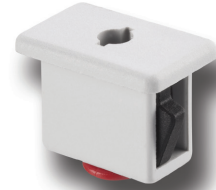

Example of application

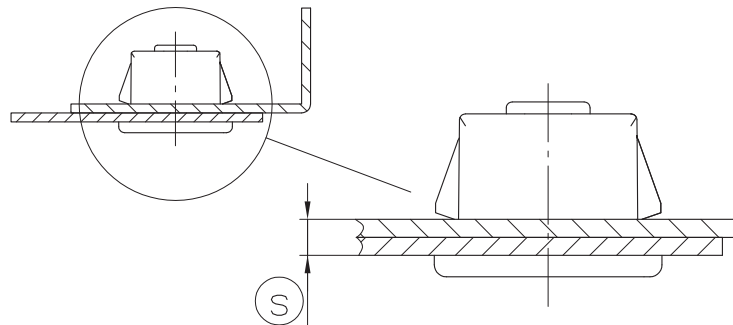

Uninstallation inside:

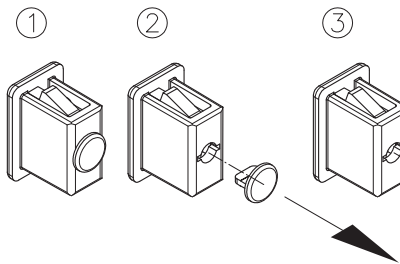

Uninstallation outside:

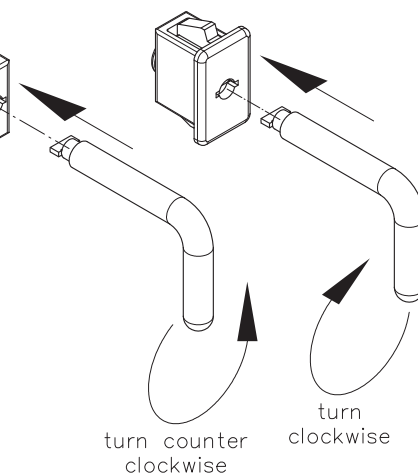

Fastener	clamping range \textcircled{S}	PA black	PA, RAL 7035 (grey)	see page
	1.5 - 1.8	294-9001.00-00015	294-9002.00-00015	
	2.0 - 2.3	294-9001.00-00020	294-9002.00-00020	
	3.0 - 3.3	294-9001.00-00030	294-9002.00-00030	
	4.0 - 4.3	294-9001.00-00040	294-9002.00-00040	
Other \textcircled{S} - dimension on request!				
Tool for uninstallation		292-0302.70-00000	292-0302.70-00000	01.113