

# 1-046SL Fastener 30x10 SNAP-LINE

for cutout 30x10, one side detachable



The Fastener SNAP-LINE has one fixed side and one detachable side.

- Fastening with countersunk screws M4 or wood screws.
- Clamping range 0.8-3mm.
- The width b of the cutout can be enlarged for adjusting.
- Fastener available in 3 pull-off force options: ~15/30/50N. Fastener can be modified to obtain 70/90N.

- Blind assembly in closed profiles.
- Vibration-proof.

**Material:**

- **Fastener SNAP-LINE:** zinc die, black
- **Snap wedges:** sintered steel

**Other surfaces and colors on request!**

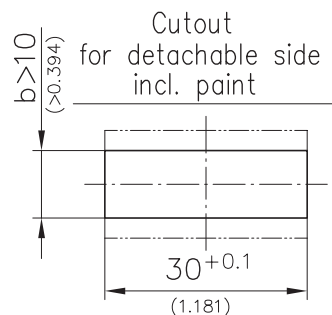
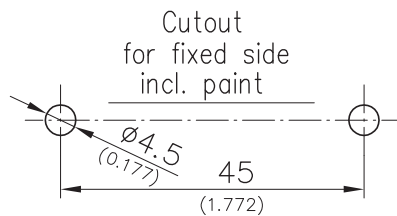
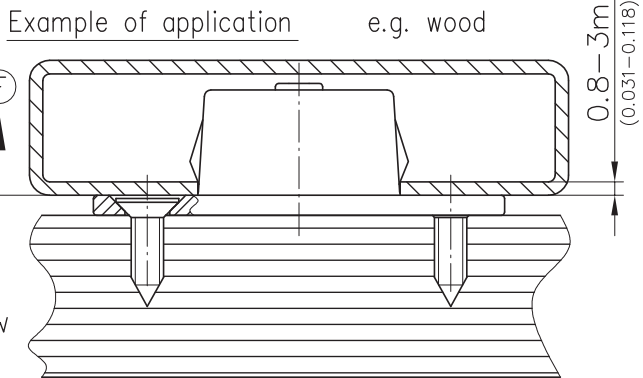
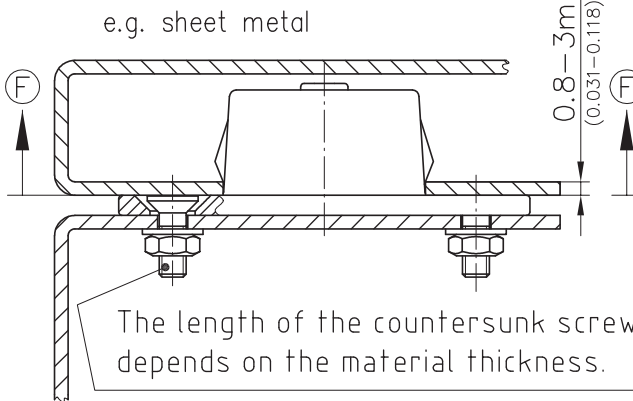
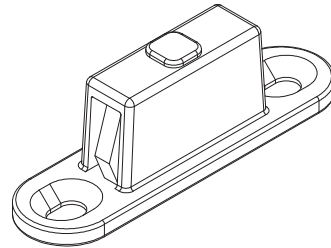
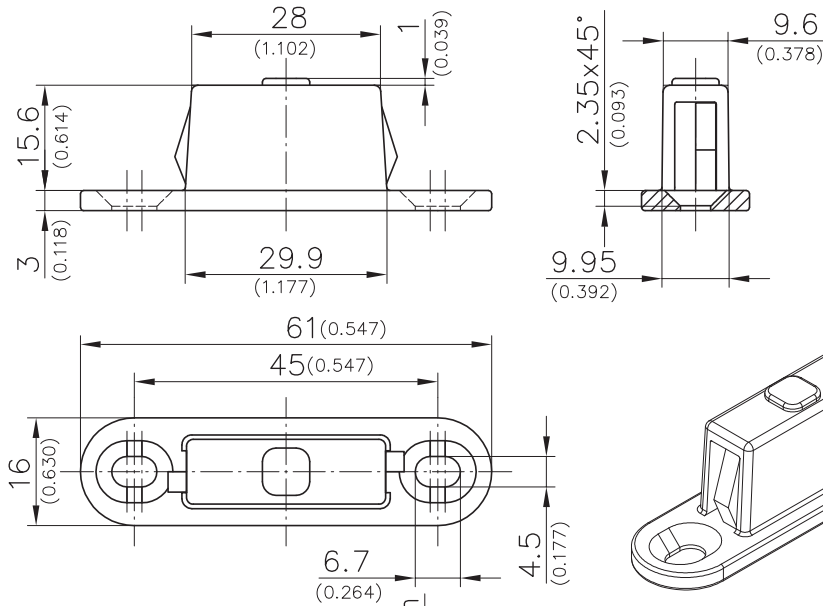

pull-off force <sup>Ⓢ</sup>	Part No.	see page
~15N	295-9002.00-00001	
~30N	295-9002.00-00003	
~50N	295-9002.00-00005	
<b>Other Dual Fastener SNAP-LINE</b>		<b>01.49, 01.50, 01.51</b>