

4-150SL Hinge Pr05 SNAP-LINE 180°

door bending 20mm, for surface mounted door, tool-less installation



180° Hinge for surface mounted door for single cabinets.

- RH and LH application.
- The door-part has 2 stubs, keeping it in position during mounting of the pin.
- Installation of the frame-part by simple push into the cutout.

Material:

- **Frame-part and door-part:** zinc die, matt black
- **Snap wedges:** sintered steel

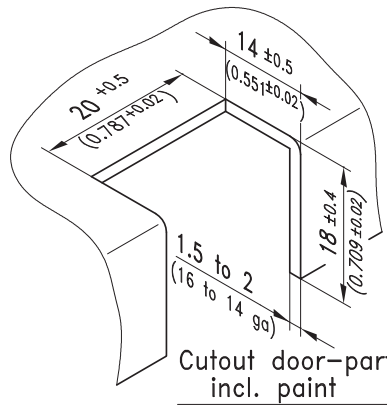
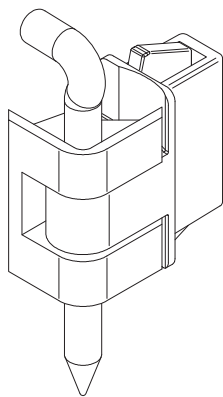
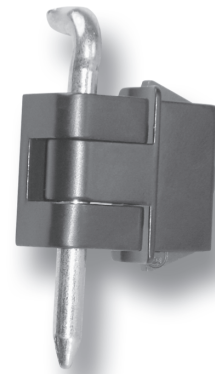

Cutout door-part incl. paint

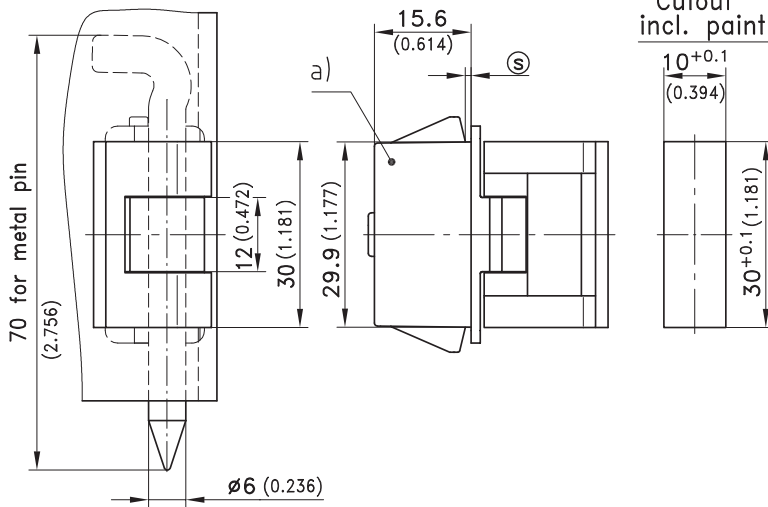
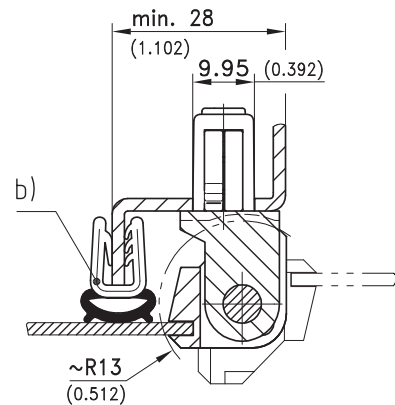

Cutout incl. paint

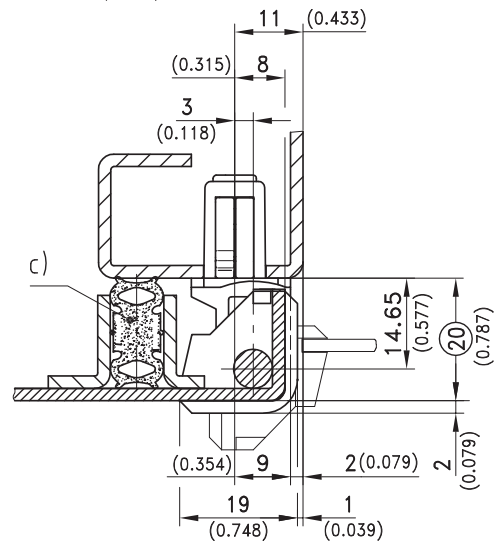

	clamping range [Ⓢ]	Part No.	see page
a) 180° Hinge	1.2 - 1.7	412-9101.00-00015	
	1.7 - 2.2	412-9101.00-00020	
	2.2 - 2.7	412-9101.00-00025	
	2.7 - 3.2	412-9101.00-00030	
POM and stainless steel on request!			
b) e.g. Gasket		209-0201.00-00000	07.19
c) e.g. Clip-on profile		209-0122.00-00000	07.08
Cover for cutout 30x10mm		292-0401.00-03010	01.110, 01.111
Reinforcement plate for cutout 30x8 and 30x10mm		292-0702.15-01030	01.112
Tool for uninstallation		292-0306.80-02530	01.113