

4-250SL Hinge Pr01 SNAP-LINE 180°

40x40mm, for nested door, tool-less installation



Hinge 40x40mm SNAP-LINE.

- The installation is effected by a simple push into appropriate cutouts.

Material:

- **Hinge halves:** zinc die, black
- **Pin:** stainless steel
- **Snap wedges:** sintered steel, zinc plated

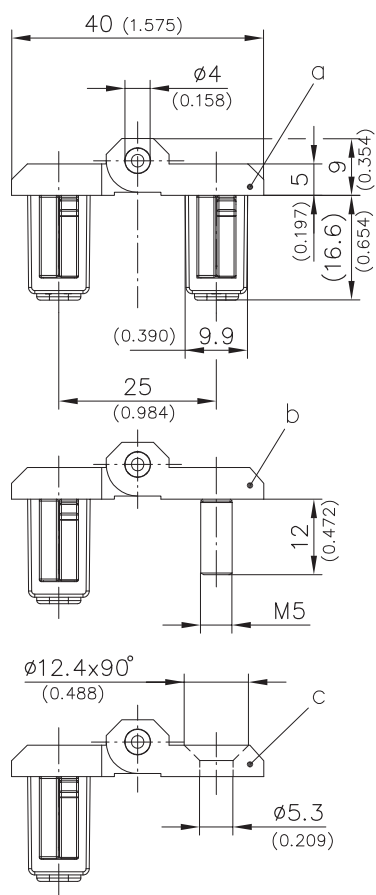
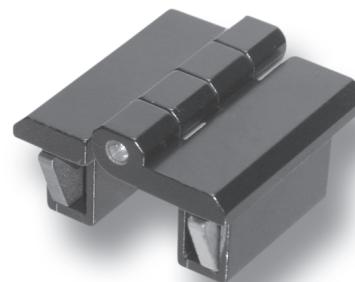

Examples of application

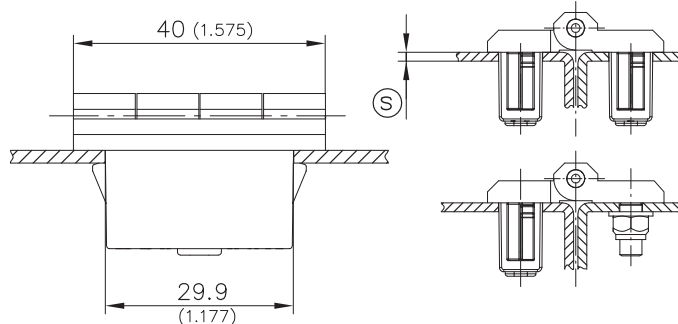

Hole pattern Frame/Door (incl. paint)

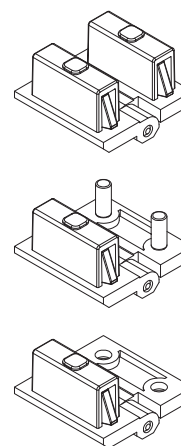
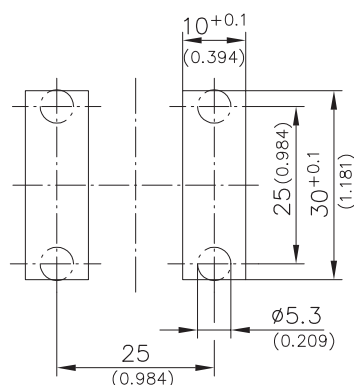

	clamping range [Ⓢ]	Part No.	see page
a) Hinge, snap-in	1.2 - 1.7	418-9001.00-00015	
	1.7 - 2.2	418-9001.00-00020	
	2.2 - 2.7	418-9001.00-00025	
	2.7 - 3.2	418-9001.00-00030	
b) Hinge, snap-in/screw-on with screws M5 molded in	1.2 - 1.7	418-9002.00-00015	
	1.7 - 2.2	418-9002.00-00020	
	2.2 - 2.7	418-9002.00-00025	
	2.7 - 3.2	418-9002.00-00030	
c) Hinge, snap-in/screw-on for countersunk screws M5	1.2 - 1.7	418-9003.00-00015	
	1.7 - 2.2	418-9003.00-00020	
	2.2 - 2.7	418-9003.00-00025	
	2.7 - 3.2	418-9003.00-00030	
d) Countersunk machine screws			09.05
e) Cover for cutout 30x10mm		292-0401.00-03010	01.110, 01.111
f) Reinforcement plate for cutout 30x8 and 30x10mm		292-0702.15-01030	01.112
g) Tool for uninstallation		292-0306.80-02530	01.113