

FDB 21 RCD/MCB

Specification

Voltage:	110V, 250V, 50Hz
Ratings:	As below
RCD:	To BS4293 where applicable.
MCB:	To BSEN60898 (Type C Characteristic) 6KA
Enclosure:	Zinc coated steel c/w knock-outs top and bottom. Protection: IP20. Finish: Light Grey epoxy powder (RAL7032).
Approx Weight:	FDB21 1.8 Kgs.

Order Reference

Current rating (amps)	Rated tripping current	
	20mA	30mA
10	21B1020	21B1030
16	21B1520	21B1530
20	21B2020	21B2030
32	21B3020	21B3030
40	21B4020	21B4030
60	21B6020	21B6030

110V Operation Suffix /110 to above Order Ref.

FDB 21

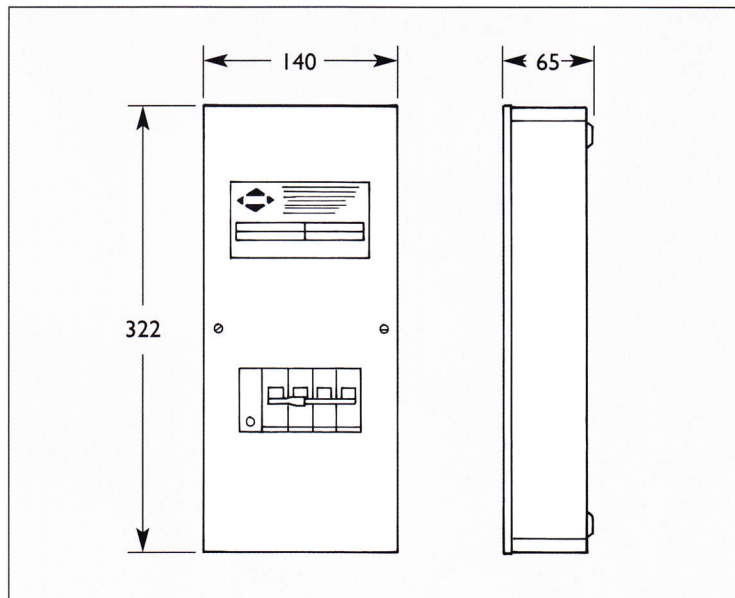

In line with our policy of constant improvements, we reserve the right to vary the specifications contained in this leaflet.

FDB Electrical Ltd
Tel: 020 8568 4621
Fax: 020 8569 7899

We manufacture a complete range of electrical safety products. Please contact us for further details.



A member of the Group owned by Findlay Durham & Brodie Ltd