

1-350 Rod Latch for Quarter-Turns L18 Pr20.1 RS/FS



snap-fit

Advantages

- Applicable for quarter-turns with housing length 18mm.
- Rod latch applicable for round or flat rods.
- Dual rod holder.
- Quick assembly of the rods.
- Installation within the sealed area of enclosures.
- RH / LH application.
- At 90° operation - stroke = 20mm.
- At 120° operation - stroke = 27,5mm (for housings without 90° stop or cams without stop, the end stop is fixed by the rack).

Materials

- Base plate: PA, black
- Driving rods, pinon: zinc die, untreated
- Washer: steel, zinc plated

Remarks

Mountable only with cam.
Use of negatively bended cams not possible.
Grounding of the quarter-turn with grounding nut possible.

1. stroke
2. matching round rods with rollers, with eye rotated by 180°, on request. (Round rods with rollers from product system 1-170 are not usable.)



Rod Latch for Quarter-Turns L18

	Part Number	Rod fastening	Installation type
a)	200-9947.00-00000	Quick-fit	snap-fit

* Accessories

- c) 1-100 Quarter-Turn Pr20.1 L18
- d) 1-100 Cam L25/45 Steel

- 1-102 Cambs L55/45 Steel
- 1-100.01 Quarter-Turn Pr20.1 L18
- b) 3-161 Flat Rod FS
- 3-910 Rod Guide FS
- 3-911 Rod Guide FS
- b) 3-160 Flat Rod FS with Rollers

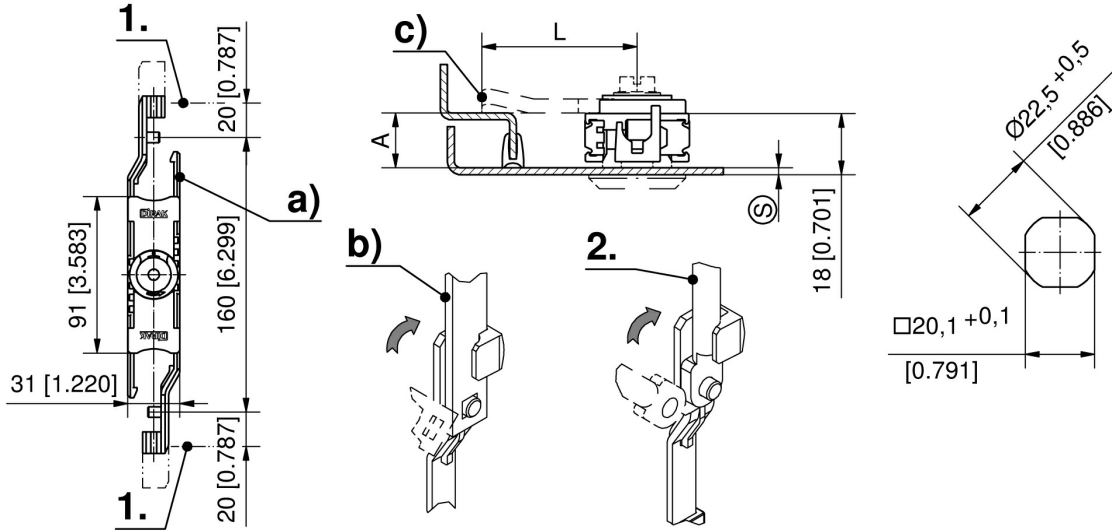

Formula for rods:
cutout in the door center

$$L = \frac{\text{clearance} - 10\text{mm [0.394] (tolerance)} - \text{Rod Latch System in retraced condition}}{2}$$

